

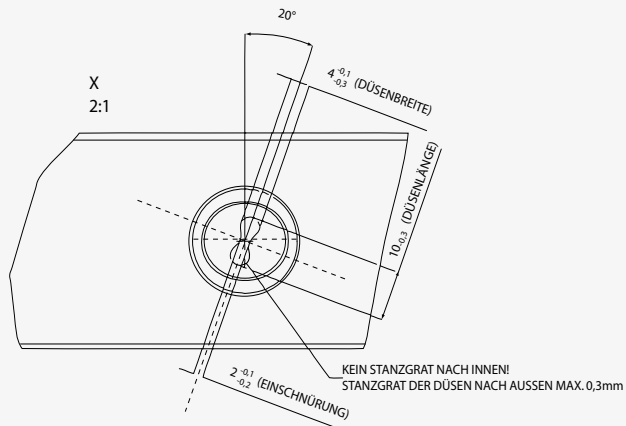

WASH WITHOUT WATER



8

7

6

1 NOBODY HAS BEEN SEARCHING FOR AMERICA.

We cannot miss what we do not know. But the history of the explorers and inventors has shown us that there is always more to discover than what you aimed for. A formula for gold had not been found but one for porcelain had – By accident!

Unlike the research in the beginning, today methodology is the centre of interest. The analysis of the parameters and its effect on the result is essential for the research success. Finally it is important to take the right steps.

Have you ever asked yourself what shape the drops of water must have to cause minimum loss of evaporation on their way from the wash arm to the plate? Our team at the Technology Center of our mother company Illinois Tool Works does! Why? Because the shape of the drops is critical to minimise loss of energy and thus reduce the total consumption of each dishwasher.

WASH WITHOUT WATER

EFFICIENT – RELIABLE – INNOVATIVE

Based on this fundamental knowledge each influencing factor can be directed to achieve the highest possible benefit. To this end, the *ITW* Technology Center benefits from more than 100 experts in various disciplines, all of whom are available to support every development team. The advantage is that solutions can be shared with other teams. Sometimes findings which could not be used in one project can then be helpful for another one.

Practice is the third step to success. Every development team is supported by an engineer from the subsidiary company. This ensures close communication and allows basic technologies to be added to your product at an early stage of development. This makes an innovative technology possible which you can afford.

Open minded thinking at the *ITW* Technology Center prevents any barriers between the different disciplines. Promising ideas are being thought through – and even tested. If a specific benefit has been discovered during a process, we try to find out how this benefit can be used to make further improvements. So, as ideas are refined the results become more revolutionary and the development faster – resulting in more than 100 HOBART patents during the last few years. Even if we cannot wash without water yet, it does not mean that it is impossible.



2 | BONDING AND DISHWASHING HAVE NOTHING IN COMMON. OR DO THEY?

Our engineers in the *ITW* Technology Center think so. A new nozzle for a hot-setting adhesive was developed for the *ITW* subsidiary company Dynatec in order to reduce adhesive consumption. At the same time this reduction made the materials softer.

The solution, a swinging nozzle was quickly developed the adhesive consumption was reduced considerably. However, as with most new inventions it wasn't a success right from the start. Among the first developments there was a design of nozzle which tended to fan out on the surface during computer simulations - useless for adhesives but brilliant for dishwashers!

At the *ITW* Technology Center there is active interdisciplinary research. The *ITW*-network allows every inventor to communicate with his colleagues.

A presentation of the "useless" nozzle prototype showed the potential of this idea of fresh water rinsing in of a dishwasher.

Finally the swinging nozzle OPTIRINSE was invented. OPTIRINSE reduces water consumption as well as energy and cleaning agent consumption by 50 %.

WASH WITHOUT WATER

EFFICIENT – RELIABLE – INNOVATIVE

3 | HOBART IS ON THE RIGHT TRACK – AND THAT'S OFFICIAL!

The development of the fresh water rinsing 50PERCENT is one of the success stories which encourages us to aim high, higher than most would think possible. Washing without water is impossible? But then some would think it was also impossible to save 50 % in one step of development.

Intensive basic research, inclusion of new, advanced technologies in the products, and continual reviewing and checking what we have achieved so far, have made HOBART leaders in the market and in technology. HOBART would not be HOBART if we didn't think ahead. Together with one of Germany's advancing technical colleges in Münster HOBART has initiated the research project REWARD-Research on **E**nergy, **W**ater and Cleaning **A**gent **R**eduction in Commercial **D**ishwashers.

The aim of this research is to reduce water and energy consumption by another 50 %, as these resources become more and more expensive. Basic research is the starting point: water filtration, ozone and ultrasonic process are just a few items for development.

Besides HOBART, the technical college in Münster and the University of Leunen (Belgium), there is an international group of young and innovative companies which participates in at this research assignment with a total of 1.8 Mio Euros. Within its Cooperative Research Program, the European Community has evaluated REWARD as one of the most important and supports it with 1.2 Mio Euros.

HOBART



WASH WITHOUT WATER

EFFICIENT – RELIABLE – INNOVATIVE

4 | THE RESULT

The first motor-driven coffee mill came to the market in 1903, with just one aim: to make daily work in the kitchen easier - ergonomically and economically. This mill was a HOBART-invention.

Still today this aim is our motivation to move forward and to strengthen our market leading position. PREMAX is the first dishwasher to incorporate revolutionary technology. The latest models offer numerous worldwide innovations and patents - exclusive to HOBART.

Fresh water rinsing 50PERCENT. Energy management TOP-TEMP. Drying manager PERFECT. Door opening VAPOSTOP. These are only a few of more than 100 patents or patents pending incorporated in the new HOBART PREMAX generation.

Without being prepared to invest in the future, without being disciplined and without sound interdisciplinary research and understanding of customers' needs, PREMAX would not be possible. And with the *ITW* Technology Center anything is possible – especially as HOBART knows what the market requires and what our customers want.

When eventually a machine is designed to be able to wash without water, you can be sure it will be a PREMAX.

HOBART: EFFICIENT – RELIABLE – INNOVATIVE!

WAREWASHING

COOKING

FOOD PREPARATION

WASTE TREATMENT

SERVICE

HOBART GMBH

Robert-Bosch-Straße 17

77656 Offenburg/GERMANY

Phone +49(0)781.600-28 20

Fax +49(0)781.600-28 19

email: info-export@hobart.de

www.hobart-export.com

EFFICIENT – RELIABLE – INNOVATIVE

Member of the *ITW* Food Equipment Group Europe

